

# SEPARATOR H9XF

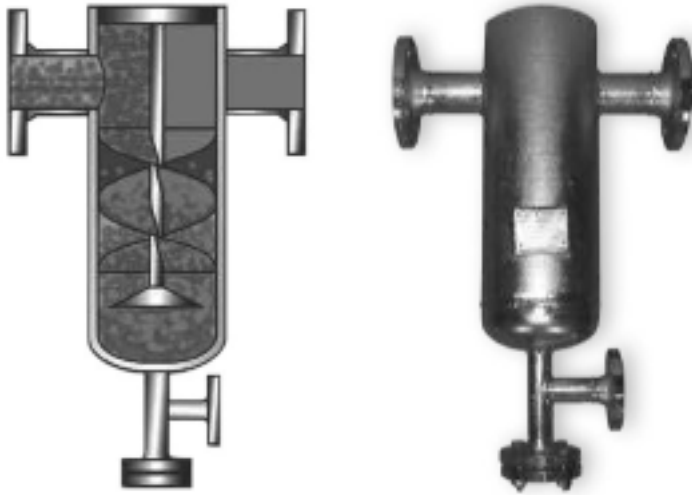

- Suitable for all steam and air lines

## Features

1. Separates mist and condensate from steam and air lines
2. Compact size - easy installation together with Pressure Reducing Valves and Steam Traps.
3. Very low pressure loss (0,002 MPa)

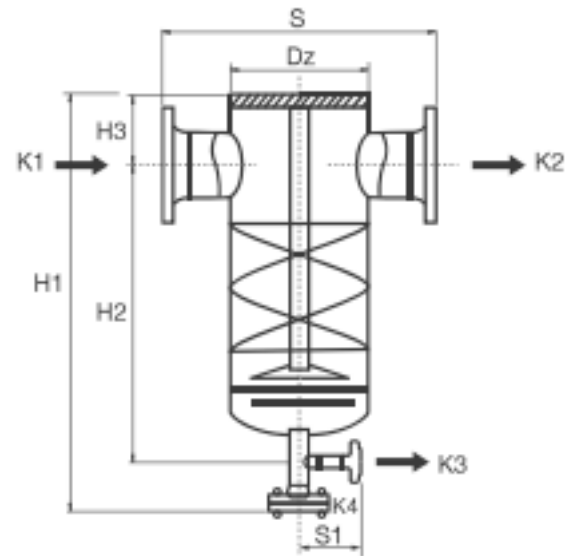

## Dimension

Model	Connection	Size (DN)	PN	Inlet K1 (DN)	Outlet K2 (DN)	Condensate Outlet K3 (DN)	Dirt Pocket K4 (DN)	Dimensions (mm)						Body Material	Weight kg																	
								Dz	H1	H2	H3	S	S1																			
UK H9XF	Flange DIN,ASME	15	16	15	15	15	15	88,9	360	240	50	240	90	SS304	6,2																	
		20		20	15											15	88,9	360	240	50	240	90	6,2									
		25		25																				15	15	114,3	460	320	70	310	90	6,2
		32		32																												
		40		40	25	25	168,3	640	440	100	420	110	6,2																			
		50		50												25	25	168,3	640	440	100	420		110	6,2							
		65		65	20	32	273	920	750	170	480	120														6,2						
		80		80												20	32	273	920	750	170	480		120			6,2					
		100		100	25	40	323,9	1040	735	185	620	140																6,2				
		125		125												25	40	323,9	1040	735	185	620		140					6,2			
150	150	on request						6,2																								
200	200	on request							6,2																							